

High Accuracy Measuring Station

MS AXII Series

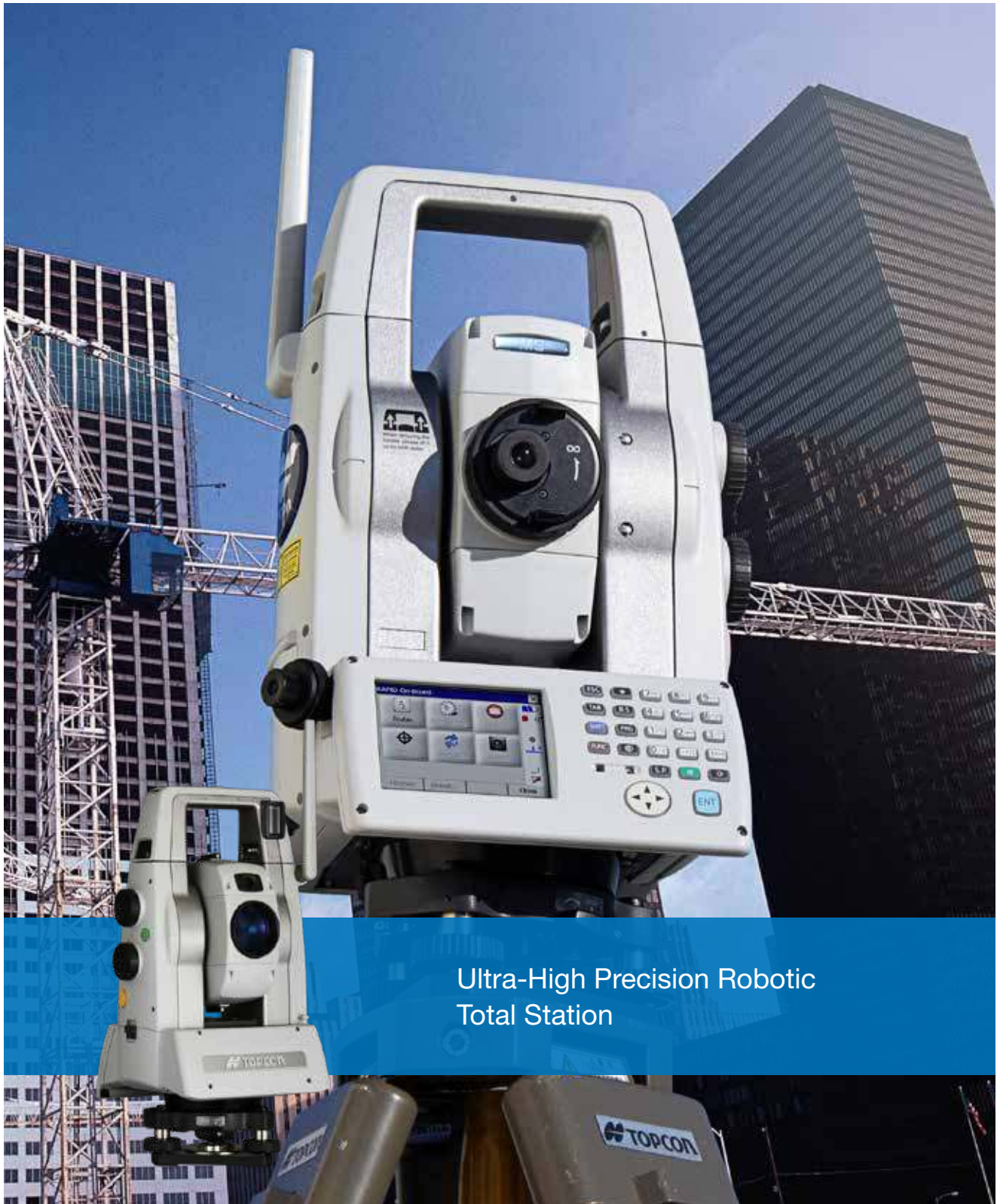

Ultra-High Precision Robotic
Total Station

High Accuracy Measuring Station

MS AXII Series

Rapid 2D Monitoring®

In addition to natural hazards, such as harsh weather, soil movement or change of ground water level, engineering structures, such as buildings, dams, tunnels and bridges can always be affected by movement caused by excavation, heavy construction and piling placement. The MS Series provides superior measuring precision and is equipped with environmental protection and functions necessary in monitoring applications, allowing it to be utilized in a high-precision monitoring solution.

Industrial measurement

The MS05 AXII, when using reflective sheet targets, can achieve sub-millimeter accuracy allowing for measuring the shape and alignment of large-scale structures such as plants and bridges, as well as precise measurements of ships, railroad cars, and airplanes.

First-order survey

The MS Series offers high-precision angle accuracy (MS05 AXII: 0.5", MS1 AXII: 1") which can be used for a wide range of precise measurements. Equipped with an automatic tracking system, the high-precision robotic measuring station can be configured with a remote control system.

Precise angle accuracies 0.5" (MS05AXII) and 1" (MS1AXII)

Auto-aiming accuracy of 1"

Remote control through on-line PC

Exclusive reflector prescan technology

Enforced durability for long term deformation and monitoring applications





- | | | |
|------------------------------|---|---------------------------|
| 1 LongLink™ communications | 5 Horizontal and vertical tangents | 8 Illuminated keyboard |
| 2 Advanced angle accuracy | 6 Li-ion rechargeable camcorder style battery | 9 Large TFT LCD |
| 3 IP65 dust and water rating | 7 Windows® Compact 7 | 10 RS-232 and power ports |
| 4 30x magnification | | |

Advanced auto-pointing algorithm for multiple prisms

Incorporating an advanced auto-pointing algorithm*, optimized for monitoring applications, it automatically sights the prism closest to the telescope center regardless of the distance from the instrument. This works even if multiple prisms or other reflective objects are in the field of view, dramatically enhances the reliability in periodic monitoring of predetermined prism locations.

Reflector prescan for monitoring setup

The MS Series automatically searches within the predetermined area to quickly measure the reflectors as initial positions for subsequent routine measurements. This function works in low light or dark conditions where the reflectors cannot be clearly seen by the human eye.

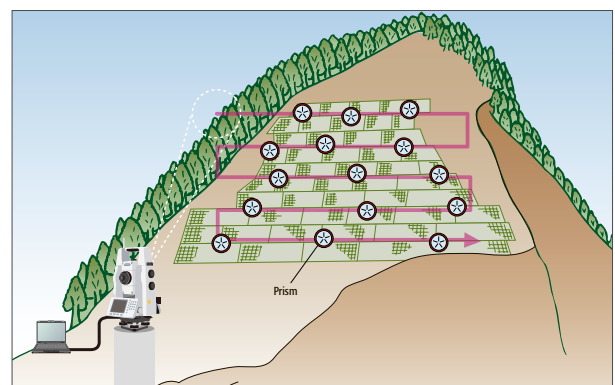



Ultra high-precision distance measurement MS05AXII

Using reflective sheet targets, the MS05 AXII provides sub-millimeter accuracy (0.5 mm + 1 ppm) in a range of up to 200 m. The MS1 AXII is doubled to 400 m with Kodak white side (90% reflective).

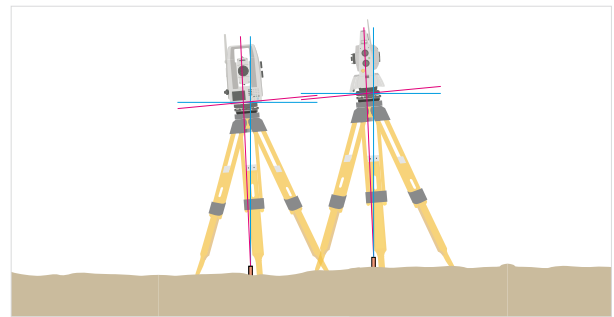

Adjusting mechanism for angle measuring

The biaxial level compensation mechanism has a wider adjusting range of $\pm 6'$ which is twice as wide, compared with previous models. This enables highly accurate measuring performance.

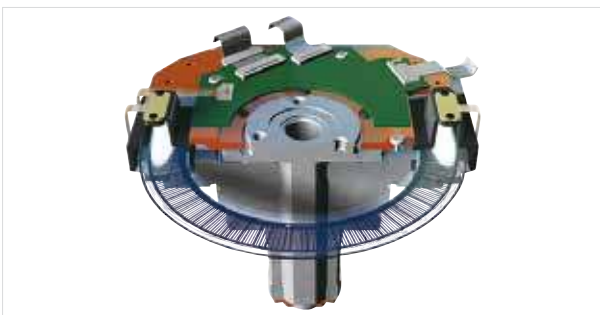

Advanced angle calibration

Topcon advanced angle encoder technology with exclusive calibration system provides "best in class" angle accuracy, 0.5" (MS05 AXII) and 1" (MS1 AXII).



Superior auto-pointing accuracy

The auto-pointing accuracy* with the standard prism is 1" (1 mm at 200 m), and 4" (1 mm at 50 m) with a reflective sheet.

*Auto-pointing accuracy is verified using the methods specified by ISO 17123-3.

- Kit Components** • MS Measuring Station • 2x Batteries and charger • Lens cap and hood • Tool kit • Plumb bob
• Digital manual • Vinyl cover • Carry case and straps



Specifications subject to change without notice.
© 2022. Topcon Positioning Systems, Inc.
All rights reserved. 7010-2083 G EU 05/22

www.topconpositioning.com/ms-series

FIELDWORK

Systèmes de guidage d'engins et systèmes de relevé

TOPCON | AUTHORIZED DEALER

Bleichelstrasse 22 | CH-9055 Bühler | +41 71 440 42 63 | info@fieldwork.ch